



**ANNOVI[®]
REVERBERI**
The Power of Experience

**AR 115 bp
AR 135 bp
AR 115/1000 bp**



**MANUALE D'USO E INSTALLAZIONE / INSTRUCTION MANUAL
NOTICE D'UTILISATION ET INSTALLATION
MANUAL DE USO E INSTALACIÓN
BETRIEBS- UND INSTALLATIONSANLEITUNG**

**Dati tecnici e prestazioni - Technical and Performance Data - Données techniques et performances
Datos técnicos y prestaciones - Technische Daten und Leistungsmerkmale**

| Modello Model Modèle Modell Modelo | Portata max Max. flow Débit max. Max. Fördermenge Caudal máx. | | Pressione max Max. pressure Pression max. Max. Druck Presión máx. | | N° giri max Max. rpm Nbre tours max. Max. Drehzahl R.p.m. máx. | Temperatura max Max. temperature Température max. Max. Temperatur Temperatura máx. | | Peso Weight Poids Gewicht Peso | |
|------------------------------------------------|---------------------------------------------------------------------------|--------------|-------------------------------------------------------------------------------|-----|----------------------------------------------------------------------------|------------------------------------------------------------------------------------------------|-----|--------------------------------------------|------|
| | L/1' l/min | gpm U/min | bar | psi | | °C | °F | kg | lb |
| AR 115bp | 107,9 | 28,5 | 20 | 290 | 550 | 60 | 140 | 15,5 | 34,2 |
| AR 135bp | 128 | 33,8 | 20 | 290 | 550 | 60 | 140 | 15,5 | 34,2 |
| AR115/1000bp | 94 | 24,8 | 15 | 220 | 1000 | 60 | 140 | 15,5 | 34,2 |

**Istruzioni originali
Original instructions
Notice originale
Originalanleitung
Instrucciones originales**

Edizione - Edition - Édition - Ausgabe - Edición: 01/2016

N° codice manuale
Manual code no.
N° code de la notice
Kode der Betriebs-und
Installationsanleitung
N° código manual

91399



CONTENTS

| | |
|-------------------------------------------|----|
| GENERAL INFORMATION | 22 |
| TECHNICAL INFORMATION | 24 |
| SAFETY INFORMATION | 27 |
| HANDLING AND TRANSPORT INSTRUCTIONS | 28 |
| INSTALLATION INSTRUCTIONS | 29 |
| INSTRUCTIONS FOR USE | 32 |
| MAINTENANCE INSTRUCTIONS | 33 |
| TROUBLESHOOTING | 37 |
| WARRANTY CONDITIONS | 95 |

INDEX OF CONTENTS

| | | | |
|--------------------------------------------------------|----|----------------------------------------------------------|----|
| After-Sales service procedures | 23 | Residual risks | 25 |
| Annexed documentation | 23 | Safety devices | 25 |
| Checking the inflation pressure | 35 | Safety recommendations for handling and lifting | 28 |
| Checking the oil level | 34 | Safety recommendations for installation | 28 |
| Declaration of Incorporation | 26 | Safety recommendations for maintenance | 33 |
| Disclaimer | 23 | Safety recommendations for use | 32 |
| Environmental operating limits | 26 | Scrapping the pump | 36 |
| General description | 24 | Starting and stopping the pump | 32 |
| General guidelines on water supply connection | 30 | Storage | 28 |
| General safety rules | 27 | Table of lubricants | 34 |
| Glossary | 23 | Technical Data | 26 |
| Inspecting the connections and pipes | 34 | Transport | 28 |
| Inspecting the Filter | 34 | | |
| Inspecting the pump mounting | 34 | | |
| Installation | 29 | | |
| Installation diagram (guideline) | 31 | | |
| Intended uses | 25 | | |
| Lengthy pump lay-offs | 36 | | |
| Main components | 24 | | |
| Misuses | 25 | | |
| Mounting the pump | 29 | | |
| Overall dimensions | 26 | | |
| Packaging description and unpacking | 28 | | |
| Preliminary checks | 32 | | |
| Pump and manufacturer identification | 22 | | |
| Purpose of the manual | 22 | | |
| Putting the pump back into service | 36 | | |

Purpose of the manual

The manufacturer has provided this manual to provide the operating instructions and the criteria to be complied with when installing, using and maintaining the pump identified by designation on the cover. The manufacturer supplies the original instructions in Italian.

The manufacturer may supply the original instructions in other languages in response to statutory or commercial requirements.

If the pump is sold, the seller must pass on this manual to the new owner along with the appliance.

The instructions are intended for the skilled, suitably trained operators who carry out the installation and routine maintenance procedures.

Refer to the table of contents for rapid access to the topics covered.

The manufacturer reserves the right to amend the manual without notice, unless the amendments refer to the pump's level of safety.

The purchaser must ensure that the installation is designed in accordance with the instructions in this manual, statutory requirements, and the relevant national and local regulations.

The technical instructions in this "Use and Installation Manual" are the property of the manufacturer and must be treated as confidential.

The symbols shown and described below are used to identify safety risks or important information.

Danger - Warning

Identifies information or procedures the failure to comply with which may constitute a serious threat to health and safety.

Caution - Take Care

Identifies information or procedures the failure to comply with which may constitute a threat to health and safety or cause damage.

Information

Identifies useful and important information or procedures which should be borne in mind.

Pump and manufacturer identification
Data plate

The data plate shown here, containing essential information for safe operation, is affixed to every pump.

- A) Manufacturer's name and address
- B) Model
- C) Serial number
- D) Maximum delivery rate (l/min)
- E) Maximum operating pressure (bar)
- F) Maximum rpm
- G) Lubricant specifications
- H) Pump code:

Manufacturer's name and address

Annovi Reverberi Spa
Via Martin Luther King, 3
41122 Modena (MO) - Italy

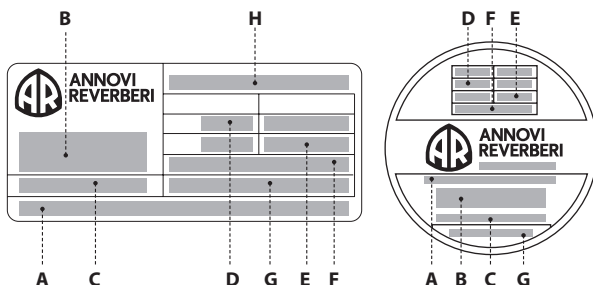



After-Sales service procedures

To request after-sales service (in the event of a pump malfunction or failure, etc.) contact your nearest service centre or the manufacturer.

When requesting after-sales services, always state the pump's data plate data and the type of problem.

Disclaimer

The manufacturer accepts no liability arising from:

- incorrect installation;
 - improper use of the pump;
 - failure to service the pump;
 - unauthorised modifications and/or repairs;
 - use of non-original spare parts, or parts not specifically intended for the model.
-

Annexed documentation

The following documentation is issued to the Customer together with this manual:

- declaration of incorporation
-

Glossary

Installer: authorised technician having the prerequisites and the specific skills required for the tasks involved in the installation of the pump and/or similar machinery and for the performance of the routine maintenance operations in conditions of safety, independently and without risk.

Operator: authorised person having the prerequisites, skills and information needed for use of the pump or the machine or plant on which the pump is installed, and for routine maintenance procedures.

Purchaser: individual, organisation or company which has purchased the pump and intends to use it for the intended purposes.

Repairs: all operations performed to conserve the pump's efficiency and operating characteristics. These procedures, required in the event of an unexpected malfunction, must only be carried out by a skilled technician. The information for the use of skilled repair technicians only is provided in the "Repairs Manual".

Routine maintenance: all operations required to keep the pump in good working order, to ensure a longer working life and maintain compliance with safety requirements. The manufacturer describes the maintenance procedures and intervals in this "Use and Installation Manual".

Training: a phase necessary to transfer to the operators the knowledge needed for the correct, risk-free performance of operations.



Information

There may be differences between the illustrations and the pump's actual conformation, but any such differences will not affect the clarity of the instructions. If in doubt, request the necessary explanations from the manufacturer.

General description

The pump is designed and constructed to pump and compress liquids on spraying machines for the protective treatment of agricultural crops and garden plants.

The pump incorporates radial pistons which actuate the diaphragms by means of an oil cushion. The diaphragms are connected to the pistons in their middles by means of plates and secured at the edges between the cylinder liner and head.

The motion of the piston draws the diaphragm inward (intake) and then outward (delivery). The flow of liquid is regulated by the intake and delivery valves.

Oil between the pump body and diaphragm serves not only as a lubricant but also as a pressure compensation medium.

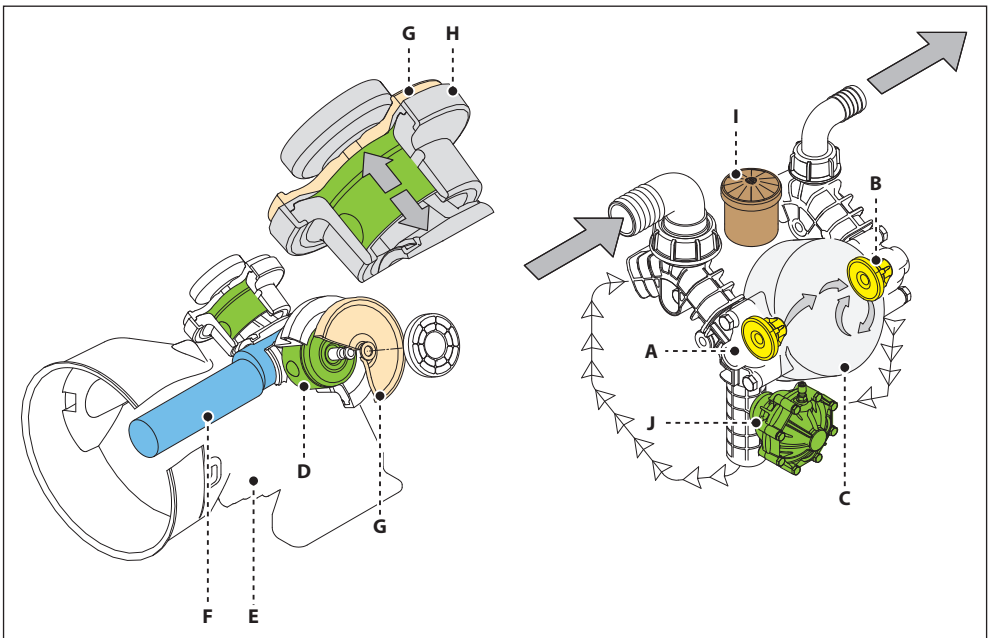
Main components

- A) Intake valve
- B) Delivery valve
- C) Head
- D) Piston
- E) Pump body
- F) Crankshaft
- G) Diaphragm
- H) Cylinder liner
- I) Oil tank
- J) Pressure accumulator

Intended uses

The pump is designed and constructed for incorporation in plants and machinery (spraying machines for the protective treatment of agricultural crops and garden plants). **All other uses constitute misuse unless approved by the manufacturer's technical service**

The pump must be used in a manner appropriate to its technical data (see "Technical Data"), and must not be modified or improperly used.

Misuses

Do not put the pump into service until the plant or machinery in which it is incorporated has been declared compliant with the relevant national and local legal requirements.

Do not use the pump in a potentially explosive atmosphere.

Do not use the pump for flammable, toxic or corrosive liquids or liquids with unsuitable density, especially seawater, adhesives, bitumens, liquefied gases or solvents of any kind, paints of any kind or liquids containing solids in suspension, and in all cases **do not** use with any liquid unless certain that it is compatible with the materials used in the pump circuit.

Do not draw in liquids at temperatures above 50°C or below 5°C.

Do not use the pump in drinking water supply systems.

Do not use the pump on products for human consumption.

Do not use the pump on pharmaceutical products.

Do not use the pump without first checking that the intake and delivery circuit pipelines are correctly secured and free from leaks.

Do not use the pump without the safety devices provided: guards for shafts and drive couplings and suitably rated relief valve on the delivery circuit.

Do not use the pump to wash or spray: people, animals or delicate items, live electrical equipment or chemicals whose characteristics are not known.

Safety devices



Danger - Warning

Never tamper with or by-pass the safety devices. Maintain all safety devices regularly to ensure they all work efficiently.

The drawing shows the position of the safety devices mounted on the machine.

Additional safety devices must be added as necessary during the design phase (see "Installation information").

A) Fixed guard: provides protection against accidental contacts with the drive shaft when in operation.

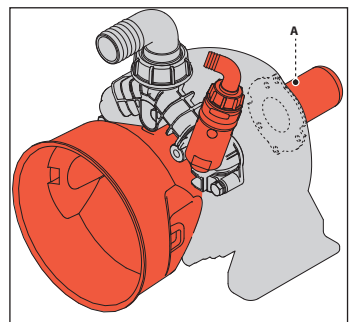

Residual risks

Even if the safety regulations and information provided in the manual are complied with, the residual risks described below are still present during use of the pump.

- **High temperature hazard:** depending on the temperature of the liquid pumped, the pump may reach high temperatures when in operation. The designer of the installation must therefore bear this in mind and provide the appropriate measures and warning signs for staff.

Technical Data

The technical and performance data are stated on the cover.

Overall dimensions

The illustrations showing the overall dimensions are provided in the annexes.

Environmental operating limits

The pump operates correctly at an ambient temperature between 5 and 50 °C.

Declaration of Incorporation

The illustration shows a copy of the declaration of incorporation, the original of which is issued by the manufacturer together with this manual.

DECLARATION OF INCORPORATION
Directive 2006/42/EC (Annex II B) and subsequent amendments
The Manufacturer

Annovi Reverberi S.p.A.
Via Martin Luther King, 3 - 41122 - Modena - Italia

Declares under its own responsibility that the Partly Completed Machinery :

Description : Diaphragm pump

Serial number : XXXX

Year of manufacture : XXXX

Complies with the following essential safety requirements specified in Annex I of Dir. 2006/42/CE :

1.1.1-1.1.2-1.1.3-1.1.5-1.1.6-1.1.7-1.2.1-1.2.2-1.3.1-1.3.2-1.3.3-1.3.4-1.3.6-1.3.7-1.3.8-1.4.1-1.4.2.1-1.4.3-1.5.4-1.5.5-1.5.6-1.5.8-1.5.9-1.5.13-1.6.1-1.6.3-1.6.4-1.6.5-1.7.1-1.7.2-1.7.3-1.7.4

It declares also that the relevant technical documentation has been compiled in accordance with the part B of Annex VII and that it undertakes to transmit, in response to a reasoned request by the national authorities, relevant information about the partly completed machinery in paper or electronic format.

Prohibiting the put into service of the partly completed machinery until the final machinery into which it is to be incorporated has been declared in conformity (where appropriate) with the provisions of the 2006/42/CE Directive and subsequent amendments.

The following Harmonized Standards have been consulted for the compliance verification :

EN 809 EN ISO 4254-1 EN ISO 4254-6

The person authorized to compile the relevant technical documentation:

Modena
07/04/2010

Reverberi Ing. Stefano
Managing Director

Annovi Reverberi S.p.A. Via Martin Luther King, 3 - 41122 Modena (MO) - Italia
Tel. +39 059 414 411 - Fax +39 059 253 505 - E-Mail : agricoltura.it@annovireverberi.it - Web : www.annovireverberi.it



General safety rules

Most workplace accidents and injuries are caused by carelessness and failure to comply with common sense and safety rules.

In most cases, accidents can be avoided by predicting their possible causes and proceeding with the necessary care and attention.

A careful operator who follows the rules is the best guarantee against accidents.

Before installing and using the pump, the operators and other staff must read and understand the instructions in the manual provided and the details of the installation design.

Do not tamper with, disarm or bypass the safety devices as this may cause serious threats to health and safety.

Do not release pollutants into the environment.

Dispose of waste in accordance with statutory requirements.

Before performing any procedure, adopt appropriate safety measures in accordance with the relevant statutory occupational safety requirements and comply with the safety regulations in the manual.



Safety recommendations for handling and lifting

Before starting the operations, organise the intended working area so that the materials can be lifted and handled in safety.

Unloading, loading, handling and lifting operations must be carried out by skilled, authorised, specifically trained staff.

During lifting and handling operations, the people not involved in the operations must remain at a safe distance.

For lifting, use hooks and ropes which are free from damage and appropriate for the load to be lifted.

Packaging description and unpacking

The packaging normally consists of a cardboard box for easy, safe transport.

Depending on the quantity of goods to be shipped and the place of destination, packages may be fixed on a pallet for easier lifting and handling.

Check the weight of the item on the transport documents to allow the use of suitable lifting equipment.

When unpacking, check that all components are present and intact. If items are missing or damaged, contact the dealer or manufacturer to agree the procedures to be followed.

The packaging material must be disposed of appropriately in accordance with the relevant statutory requirements.

Transport

The pump may be shipped by a variety of means of transport (road, rail, sea or air) depending on its destination. Secure the packaging firmly to the vehicle during transport, to prevent random movement.

Storage

In the event of a lengthy period out of use, place the pump (in its packaging if possible, or otherwise protected) under cover, protected from the weather.

Do not store in places where the ambient conditions might impair the pump's operating condition over time.

Safety recommendations for installation

Take all possible precautions to allow the pump to be installed in a safe, risk-free manner.

All installation phases must be taken into consideration when designing the machinery or plant in which the pump is to be installed.

The design must consider all mounting points, the means of transmission of the energy sources, and the protective and safety devices required by the relevant regulations to prevent the risk of injury.

Installation

The mechanical connection between the pump and the motive power source may be made by means of a pulley and belt, with a drive shaft, or through a direct flanged connection to the motive power source.

The crankshaft may turn in either direction.

The water connection between the pump and the machine circuit must be made using hoses of suitable diameter, in all cases no less than that of the pump fittings, securing them to the fittings using good quality clamps.

The intake hose must be coil-reinforced to prevent restrictions.

The machine intake circuit must be fitted with a filter having suitable capacity for the pump delivery rate and must be designed to generate a vacuum of no more than - 0.25 bar. This value can be measured by connecting a vacuummeter to the pump intake fitting.

The rated pressure of the delivery hose, fittings and clamps must be no less than the maximum rated pressure of the pump. Replacing the intake and delivery fittings provided on the pump by the manufacturer with small-diameter alternatives may reduce the pump's performance and annul the warranty.

Mounting the pump

The pump must be installed on a horizontal surface with no flexible components between it and the mounting surface.

The illustration shows the maximum permitted pump installation angle beyond which proper lubrication of the crank mechanism is not ensured.

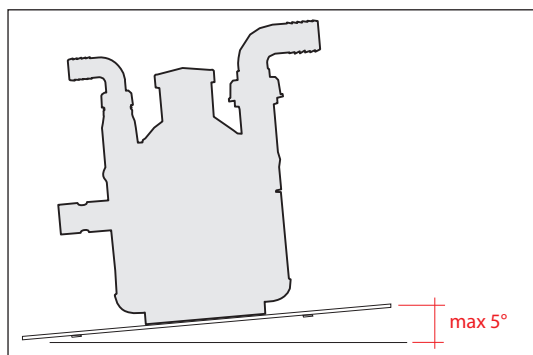

Fix the pump by screwing the pump support onto the base of the machine with suitable screws, tightening appropriately.

General guidelines on water supply connection

To operate correctly, the diaphragm pump must draw in liquids from containers at atmospheric pressure. **Do not supply the pump with pressurised liquids.**

For continuous duty, the pump should not draw in water by gravity from containers with liquid level at heights above 3 m.

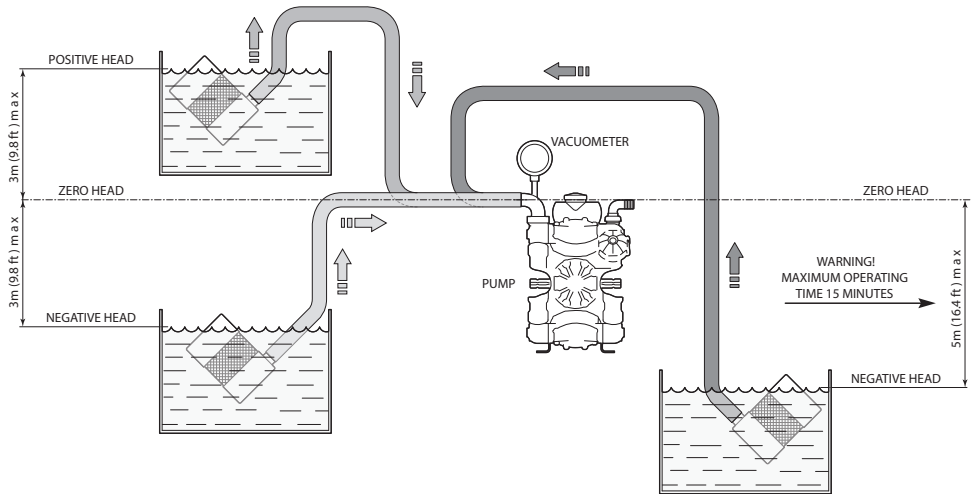

UN003415-EW

For continuous duty, the pump should not draw in liquids by vacuum from containers with the liquid level more than 3 m below the pump intake fitting and the circuit must consist of hoses of length and diameter appropriate to the pump intake fitting (see "Technical Data"), free from restrictions and elbows, and with a filter of suitable capacity (see "Installation").

For occasional duty, such as filling water supply tanks, the pump can be operated at a vacuum drawing in liquids from reservoirs having the surface of the liquid up to 5 m below the pump intake fitting, for periods of no more than 15 minutes.

Drawing in liquids from lower levels or for longer times causes cavitation in the pump circuit and reduces the lifetime of the diaphragms, valves and mechanical parts.

Installation diagram (guideline)

The following is a simplified illustration of the typical installation layout and is purely guideline.

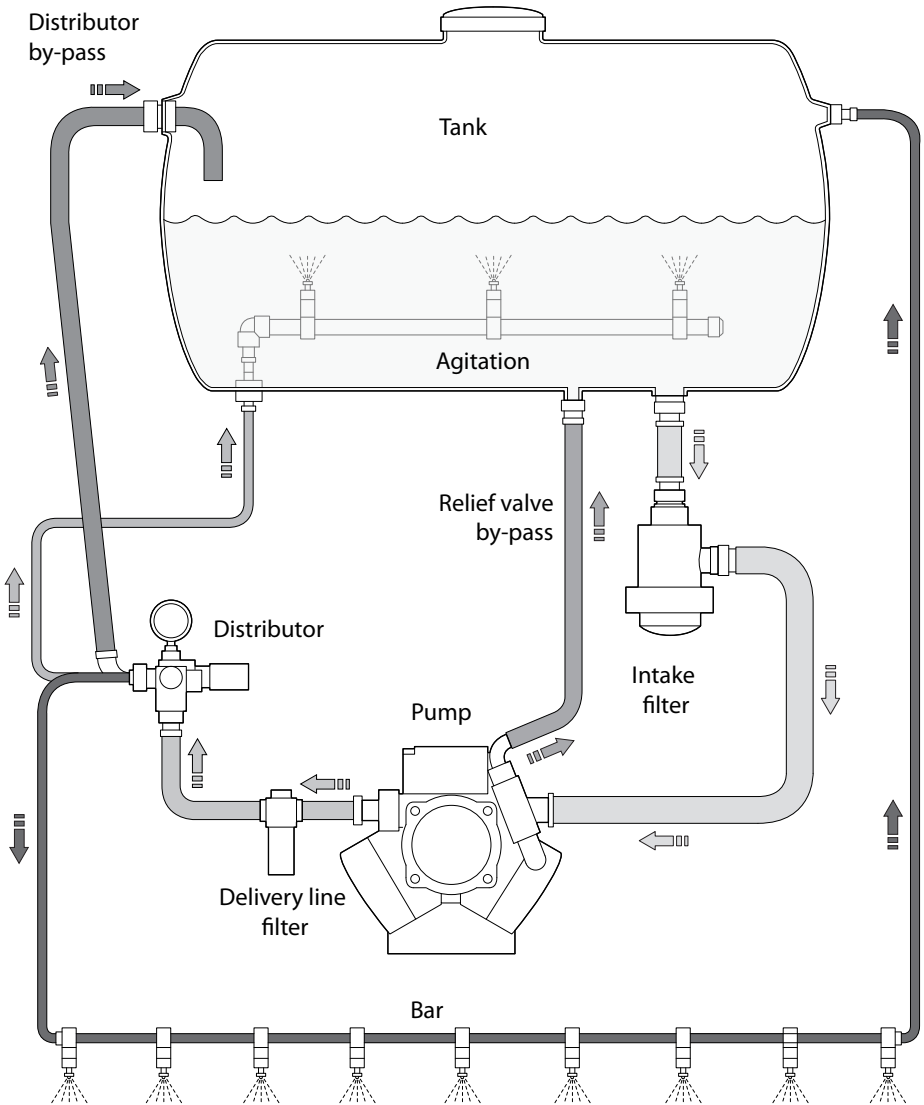



Safety recommendations for use

Before start-up, the operator must perform the necessary safety checks.

In the event of leaks from the pressurised pipes, stop the pump at once and remove the cause of the leak.

Do not operate the pump above the limits set by the manufacturer to increase its performance.

Preliminary checks

If the pump has a pressure accumulator, check its level of inflation, see "Checking the inflation pressure".

Check the fittings of the hoses and the pump's intake and delivery circuits to prevent restrictions, the intake of air and leaks of liquid.

Check that any ball valves on the pump or distributor are closed.

Before putting the pump into operation, check that the oil level in the pump tank is between the minimum and maximum lines marked on the tank.

Before putting the pump into operation, check that the pressure regulator knob is turned fully anticlockwise and the pressure distributor switching lever is in the by-pass position.

Starting and stopping the pump

To start the pump, proceed as described below.

1. When starting the pump, keep the pressure distributor switching lever in the by-pass position until the pump has primed.
2. Move the distributor switching lever into the pressure regulation position.
3. Turn the distributor knob clockwise to increase the pressure or anticlockwise to decrease it.
4. During the first few hours of operation, check that the oil level in the tank remains between the minimum and maximum limits. If top-ups are required, use oil of the type shown on the pump dataplate.

To stop the pump, proceed as described below.

1. Reduce the pressure by turning the distributor knob anticlockwise
2. Open the by-pass valve to discharge the pressure.
3. Stop the pump.

Safety recommendations for maintenance

Caution - Take Care

Before doing any maintenance work, depressurise the water system and isolate the pump from all energy sources.

When the jobs are done, before restarting the pump, check that no tools, rags or other materials have been left close to moving parts or in hazardous zones.

Replace any excessively worn components with original parts and use the lubricants recommended by the manufacturer.

Scheduled maintenance table

| Frequency | Component | Procedure | Reference |
|-------------------------|-------------------------------------------------------------|--------------------------|--------------------------------------------|
| Every working day | Filter | Inspect filter cartridge | See "Inspecting the filter" |
| | Pump | Checking the oil level | See "Checking the oil level" |
| | Connection of pump to power source (pulley, belt, coupling) | Inspection | - |
| | Pump | Inspect mounting | See "Inspecting the pump mounting" |
| | Pipes and connections | Inspection | See "Inspecting the connections and pipes" |
| Every 100 working hours | Pressure accumulator (if installed) | Check inflation pressure | See "Checking the inflation pressure" |
| | Reduction gear (if installed) | Check oil | See "Checking the oil level" |

Dispose of the worn-out components and lubricants in accordance with the relevant statutory requirements.

Carry out the routine maintenance procedures specified by the manufacturer to keep the pump safe and performing well.

Table of lubricants

The pump is delivered complete with high-performance synthetic multigrade oil suitable for the intended ambient conditions (see “Environmental operating limits”).

Inspecting the pump mounting

Check that the pump's fixing screws have not become loose.

If necessary, tighten them with the driving torque stated in the installation design.

Inspecting the connections and pipes
- Inspect the connections for leaks.

Leaks can normally be dealt with by tightening the connections properly.

If leaks from the intake pipeline connections are noticed, the seals must be repaired.

- Inspect the hoses.

If the pipes show signs of aging, breakage, swelling, rubbing, etc., they must be replaced.

Inspecting the Filter
- Inspect the filter cartridge.

If the cartridge is fouled, wash it thoroughly to remove the dirt.

If the cartridge is torn or cracked, it must be replaced.

Checking the oil level

- Check the oil with the pump level and cold.
- Check the amount of oil through the level gauge (A).

- If necessary, top up with oil with the characteristics specified in the “Lubricants table”.

To top up with oil proceed as described below.

- 1) Unscrew the plug (B) and pour oil (C) in through the hole until it is halfway up the level gauge (A).
- 2) Screw on the plug (B).

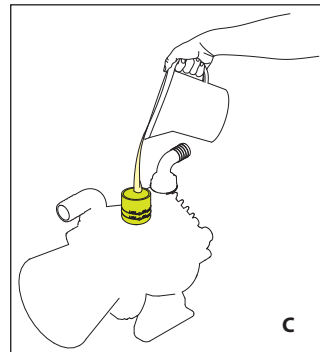
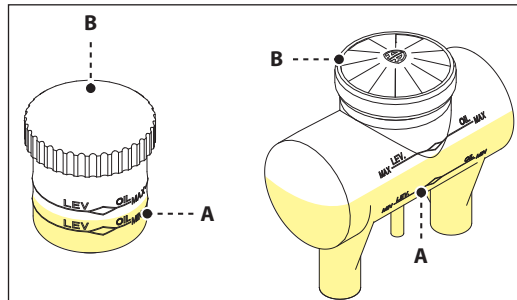

Checking the inflation pressure

If the pump has a pressure accumulator, check its level of inflation, with the pump at a standstill, using an air gun fitted with a pressure gauge. The accumulator is inflated by the manufacturer for use of the pump at its maximum pressure. For adaptation of the accumulator pressure to the working pressure, refer to the table below.

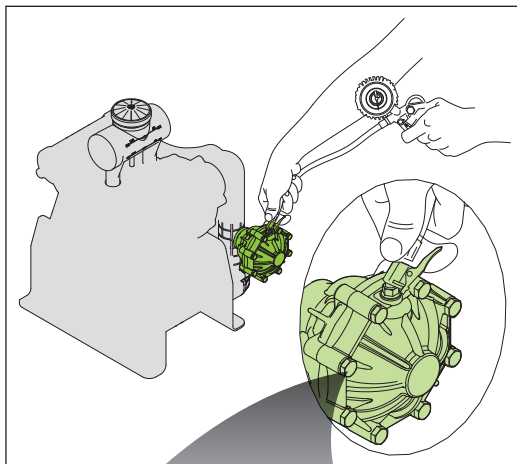

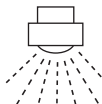
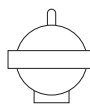
|  | |  | |
|-----------------------------------------------------------------------------------|---------|-----------------------------------------------------------------------------------|--------|
| bar | psi | bar | psi |
| 1-3 | 15-44 | 1 | 15 |
| 3-12 | 44-174 | 1-3 | 15-44 |
| 12-20 | 174-290 | 3-5 | 44-73 |
| 20-50 | 290-725 | 5-7 | 73-102 |



Lengthy pump lay-offs

It is important to comply with the recommendations for lay-offs in the operator's manual of the machine into which the pump is incorporated.

For the pump itself, at the end of pumping operations it is essential to flush out the internal circuit by pumping clean water. After this, open the intake circuit to the air and leave the pump in operation until the internal circuit is completely empty. Following this simple procedure at the end of every operating session will prevent the retention inside the pump of products which are often corrosive and may damage its hydraulic circuit in the long-term.

If the pump is laid off during the winter in locations with severe weather conditions, it is very important to flush out the internal circuit as described above and then draw diluted automotive anti-freeze into the pump. Then take care to discharge the liquid from the system and the pump in particular; it usually has a specific drain plug.

Putting the pump back into service

Before putting the pump back into service after a long period out of use, check the oil level and the tightness of the mounting screws.

Scrapping the pump

Used units must be disposed of in compliance with local legislation.

The information provided is intended to provide guidance how to deal with malfunctions which may occur during use.

Some of these procedures may be carried out by skilled staff, while others have to be performed at specialised service centres since they require the use of specific equipment as well as detailed knowledge of repair operations.

| Problem | Cause | Remedy |
|-------------------------------------------------------------------------|----------------------------------------------------|-------------------------------------------------------------------------------------------------------------------|
| The pump does not prime properly. | Intake circuit not airtight. | Tighten, repair or replace hoses and fittings as necessary. |
| | Distributor switching lever on "Pressure" setting. | Move distributor switching lever to "By-pass" setting. |
| The pump does not require the required pressure. | Seat and plate of intake and delivery valves worn. | Replace the worn valves.(1) |
| | Nozzles worn or too large in diameter. | Replace the worn nozzles. Use nozzles of suitable diameter. |
| | Restriction in intake circuit. | Remove the restriction from the circuit. |
| | Intake filter fouled. | Clean the filter cartridge. |
| Pressure gauge needle wobbles, pressure throbbing. | Intake circuit not airtight. | Clean or replace the intake and delivery valves. (1) |
| | Residual air left inside pump. | Discharge the air by opening a ball valve/central unit connected to the delivery side with the pump in operation. |
| | Valve plate stuck to its seat. | Tighten, repair or replace hoses and fittings as necessary. |
| | Pressure accumulator deflated | Inflate accumulator to the correct pressure. |
| Uneven flow of liquid to nozzles. | Pressure accumulator deflated | Inflate accumulator to the correct pressure. |
| Increase in noise and simultaneous drop in oil level (pump cavitation). | Restriction in intake circuit. | Remove the restriction from the circuit. |
| | Intake filter fouled. | Clean the filter cartridge. |
| | Pump drawing in liquid from too low a level. | See "Pump Intake Conditions" section. |

(1) Operations which must be carried out at an authorised service centre



| Problem | Cause | Remedy |
|-----------------------------------------------------------------------------------------------------------------|------------------------------------|----------------------------------------------------------|
| Oil on pump body or base. | Oil seal on pump shaft worn. | Replace the worn oil seal. (1) |
| | Oil pressure inside pump too high. | Restore correct oil level in tank. |
| Pump using too much oil (oil flowing from delivery port) or oil whitish in colour (water/oil emulsion in tank). | One or more diaphragms ruptured. | Stop the pump at once. Replace the diaphragms (1) |

(1) Operations which must be carried out at an authorised service centre